

33rd International Chemistry Olympiad

Mumbai, Tuesday, 10 July 2001

Theoretical Examination

Instructions for students

- ☞ Write your name and student code in the upper corner of the first pages of all problems and your student code on all other pages of this question paper.
- ☞ You have 5 hours to complete all the problems and record your results in the answer boxes. You must stop your work immediately after the STOP command is given. A delay in doing this by 3 minutes or more will lead to cancellation of the current problem and will result in zero points for the problem.
- ☞ All results must be written in the appropriate boxes on the pages. Anything written elsewhere will not be marked. If you need any more sheets for rough work or a replacement answer sheet, ask the supervisor.
- ☞ You must give the main steps in a calculation in the answer box provided.
- ☞ When you have finished the examination, you must put all the papers into the envelope provided, then you must seal the envelope. Only papers in the sealed envelope will be marked.
- ☞ A receipt will be issued for your sealed envelope. Do not leave the examination room until you are directed to do so.
- ☞ Use only the pen and calculator provided.
- ☞ Values of some fundamental constants and some useful information are given on page 2.
- ☞ A copy of the Periodic Table of the Elements is provided at the end of the paper.
- ☞ This examination paper consists of 39 pages of problems including answer boxes.
- ☞ An official English–language version is available on request.

Some Useful Information

Avogadro's constant $N_A = 6.022 \times 10^{23} \text{ mol}^{-1}$

Electronic charge $e = 1.602 \times 10^{-19} \text{ C}$

Molar gas constant $R = 8.315 \text{ JK}^{-1}\text{mol}^{-1}$

Planck's constant $h = 6.626 \times 10^{-34} \text{ Js}$

Speed of light (in vacuum) $c = 2.998 \times 10^8 \text{ ms}^{-1}$

1 atomic mass unit (1u) $= 931.5 \text{ MeV}/c^2$

1 Dalton $= 1.661 \times 10^{-27} \text{ kg}$

1 eV $= 1.602 \times 10^{-19} \text{ J}$

1 bar $= 10^5 \text{ Pa} = 10^5 \text{ Nm}^{-2}$

1 Å $= 10^{-10} \text{ m}$

For a sequence of first order reactions

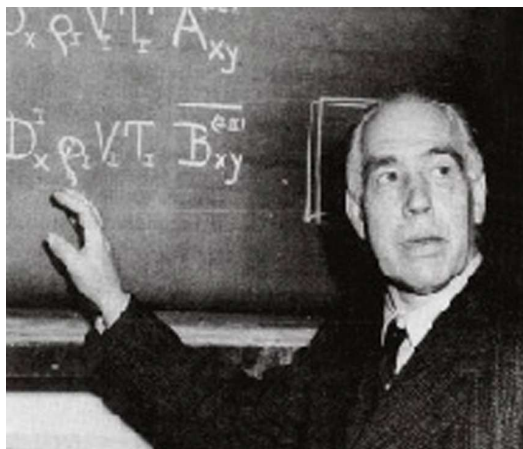

$$[B]_t = \frac{k_1[A]_0}{(k_2 - k_1)} [e^{-k_1 t} - e^{-k_2 t}]$$

33rd IChO • Problem 1**7 Points****Hydrogen Atom and Hydrogen Molecule**

Niels Bohr (1885-1962)

The observed wavelengths in the line spectrum of hydrogen atom were first expressed in terms of a series by Johann Jakob Balmer, a Swiss teacher. Balmer's empirical formula is

$$\frac{1}{\lambda} = R_H \left(\frac{1}{2^2} - \frac{1}{n^2} \right); \quad n = 3, 4, 5, \dots$$

Here, $R_H = \frac{m_e e^4}{8 \epsilon_0^2 h^3 c} = 109678 \text{ cm}^{-1}$

is the Rydberg constant. m_e is the mass of an electron. Niels Bohr derived this expression theoretically in 1913. The formula is easily generalized to any one-electron atom/ion.

- 1.1** Calculate the longest wavelength in Å ($1 \text{ Å} = 10^{-10} \text{ m}$) in the 'Balmer series' of singly ionized helium (He^+). Ignore nuclear motion in your calculation.

Longest wavelength λ_L corresponds to $n = 3$

For He^+

$$\frac{1}{\lambda} = 4 R_H \left(\frac{1}{2^2} - \frac{1}{n^2} \right) \quad (0.5)$$

$$\lambda_L = 1641.1 \text{ Å} \quad (1)$$

1.5 marks

- 1.2** A formula analogous to Balmer's formula applies to the series of spectral lines which arise from transitions from higher energy levels to the lowest energy

level of hydrogen atom. Write this formula and use it to determine the ground state energy of a hydrogen atom in eV.

$$\frac{1}{\lambda} = R_H \left(\frac{1}{1^2} - \frac{1}{n^2} \right); \quad n = 2, 3, 4, \dots \quad (0.5)$$

$$E = -hcR_H \quad (0.5)$$

$$= -13.6 \text{ eV} \quad (0.5)$$

1.5 marks

A 'muonic hydrogen atom' is like a hydrogen atom in which the electron is replaced by a heavier particle, the muon. The mass of a muon is about 207 times the mass of an electron, while its charge is the same as that of an electron. A muon has a very short lifetime, but we ignore its unstable nature here.

1.3 Determine the lowest energy and the radius of the first Bohr orbit of the muonic hydrogen atom. Ignore the motion of the nucleus in your calculation.

The radius of the first Bohr orbit of a hydrogen atom (called the Bohr radius, $a_0 = \frac{\epsilon_0 h^2}{m_e e^2 \pi}$) is 0.53 Å.

$$\text{Lowest energy} = -207 \times 13.6 = -2.82 \text{ keV} \quad (1)$$

$$\text{Radius of the first Bohr orbit} = 0.53 / 207 = 2.6 \times 10^{-3} \text{ Å} \quad (1)$$

2 marks

The classical picture of an 'orbit' in Bohr's theory has now been replaced by the quantum mechanical notion of an 'orbital'. The orbital $\psi_{1s}(r)$ for the ground state of a hydrogen atom is given by

$$\psi_{1s}(r) = \frac{1}{\sqrt{\pi a_0^3}} e^{-r/a_0}$$

where r is the distance of the electron from the nucleus and a_0 is the Bohr radius.

1.4 Consider a spherical shell of radius a_0 and thickness $0.001a_0$. Estimate the probability of finding the electron in this shell. Volume of a spherical shell of inner radius r and small thickness Δr equals $4\pi r^2 \Delta r$.

$$\text{Probability} = |\psi(a_0)|^2 4\pi a_0^2 \times 0.001 a_0 \quad (1)$$

$$= 0.004 e^{-2} \quad (1)$$

$$= 5.41 \times 10^{-4}$$

2 marks

The H₂ molecule can dissociate through two different channels:

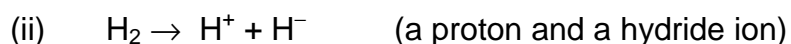
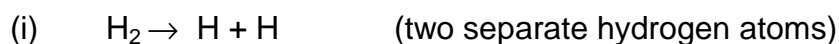

The graph of energy (E) vs internuclear distance (R) for H₂ is shown schematically in the figure. The atomic and molecular energies are given in the same scale.

1.5 Put appropriate channel labels (i) or (ii) in the boxes below.

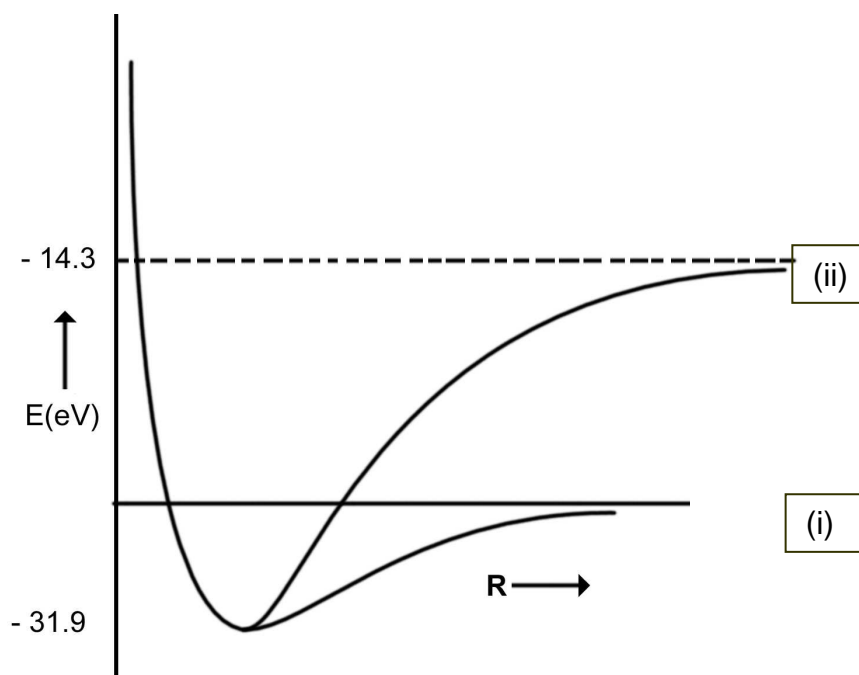
**1 mark**

1.6 Determine the values of the dissociation energies (D_e in eV) of the H₂ molecule corresponding to

channel (i)

4.7 eV

channel (ii)

17.6 eV

1 mark

- 1.7 From the given data, calculate the energy change for the process

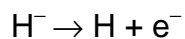

$$\text{electron affinity} = -13.6 - (-14.3) = 0.7 \text{ eV}$$

1 mark

- 1.8 H^- is a two-electron atomic system. Assuming that the Bohr energy formula is valid for each electron with nuclear charge Z replaced by Z_{eff} , calculate Z_{eff} for H^- .

$$-13.6 + 27.2 Z_{\text{eff}}^2 = 0.7 \quad (1)$$

$$Z_{\text{eff}} = 0.7 \quad (1)$$

2 marks

Name :

Student code :

33rd IChO • Problem 2

7 Points

Phosphoric Acid

Phosphoric acid is of great importance in fertiliser production. Besides, phosphoric acid and its various salts have a number of applications in metal treatment, food, detergent and toothpaste industries.

2.1 The pK values of the three successive dissociations of phosphoric acid at 25°C are:

$$\text{pK}_{1a} = 2.12$$

$$\text{pK}_{2a} = 7.21$$

$$\text{pK}_{3a} = 12.32$$

Write down the conjugate base of dihydrogen phosphate ion and determine its pK_b value.

The conjugate base of dihydrogen phosphate(H_2PO_4^-) is monohydrogen phosphate (HPO_4^{2-}): (0.5)

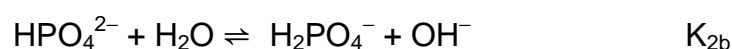
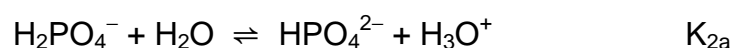

$$\text{pK}_{2a} + \text{pK}_{2b} = \text{pK}_w = 14 \quad (0.5)$$

$$\text{pK}_{2b} = 6.79 \quad (1.0)$$

2 marks

Small quantities of phosphoric acid are extensively used to impart the sour or tart taste to many soft drinks such as colas and root beers. A cola having a density of 1.00 g mL^{-1} contains 0.05 % by weight of phosphoric acid.

- 2.2 Determine the pH of the cola (ignoring the second and the third dissociation steps for phosphoric acid). Assume that the acidity of the cola arises only from phosphoric acid.

$$\text{Concentration of H}_3\text{PO}_4 = \frac{0.5}{98} = 0.0051 \text{ M} \quad (1)$$

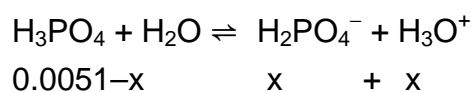

$$\text{p}K_{1a} = 2.12 \quad \text{gives} \quad K_{1a} = 7.59 \times 10^{-3} \quad (0.5)$$

$$7.59 \times 10^{-3} = \frac{[\text{H}_2\text{PO}_4^-][\text{H}_3\text{O}^+]}{[\text{H}_3\text{PO}_4]} = \frac{x^2}{0.0051-x} \quad (1)$$

$$x = [\text{H}_3\text{O}^+] = 3.49 \times 10^{-3} \quad (1)$$

$$\text{pH} = 2.46 \quad (0.5)$$

4 marks

- 2.3 Phosphoric acid is used as a fertiliser for agriculture. $1.00 \times 10^{-3} \text{ M}$ phosphoric acid is added to an aqueous soil suspension and the pH is found to be 7.00.

Determine the fractional concentrations of all the different phosphate species present in the solution. Assume that no component of the soil interacts with any phosphate species.

Let

$$f_0 = \frac{[\text{H}_3\text{X}]}{C}, \quad f_1 = \frac{[\text{H}_2\text{X}^-]}{C},$$

$$f_2 = \frac{[\text{HX}^{2-}]}{C} \quad \text{and} \quad f_3 = \frac{[\text{X}^{3-}]}{C}$$

denote the fractional concentrations of different phosphate species. C is the total initial concentration of H_3X . ($X = PO_4$)

$$f_0 + f_1 + f_2 + f_3 = 1$$

$$K_{1a} = \frac{[H_2X^-][H_3O^+]}{[H_3X]} = \frac{f_1}{f_0} [H_3O^+]$$

$$K_{2a} = \frac{[HX^{2-}][H_3O^+]}{[H_2X^-]} = \frac{f_2}{f_1} [H_3O^+]$$

$$K_{3a} = \frac{[X^{3-}][H_3O^+]}{[HX^{2-}]} = \frac{f_3}{f_2} [H_3O^+]$$

These equations lead to

$$f_0 = \frac{[H_3O^+]^3}{D}, \quad f_1 = \frac{K_{1a}[H_3O^+]^2}{D}$$

$$f_2 = \frac{K_{1a}K_{2a}[H_3O^+]}{D}, \quad f_3 = \frac{K_{1a}K_{2a}K_{3a}}{D}$$

(2)

$$\text{where } D = K_{1a}K_{2a}K_{3a} + K_{1a}K_{2a}[H_3O^+] + K_{1a}[H_3O^+]^2 + [H_3O^+]^3$$

From the values of pK_{1a} , pK_{2a} , pK_{3a} and pH , one gets

$$K_{1a} = 7.59 \times 10^{-3}; \quad K_{2a} = 6.17 \times 10^{-8}; \quad K_{3a} = 4.79 \times 10^{-13}$$

$$[H_3O^+] = 10^{-7}$$

(1)

The fractional concentrations of different phosphate species are

$$H_3PO_4 \quad (f_0) = 8.10 \times 10^{-6}$$

$$H_2PO_4^- \quad (f_1) = 0.618$$

$$HPO_4^{2-} \quad (f_2) = 0.382$$

$$PO_4^{3-} \quad (f_3) = 1.83 \times 10^{-6}$$

(2)

5 marks

- 2.4 Zinc is an essential micronutrient for plant growth. Plants can absorb zinc in water soluble form only. In a given soil water with pH = 7.0, zinc phosphate was found to be the only source of zinc and phosphate. Calculate the concentration of $[\text{Zn}^{2+}]$ and $[\text{PO}_4^{3-}]$ ions in the solution. K_{sp} for zinc phosphate is 9.1×10^{-33} .

Let $S \text{ mol L}^{-1}$ be the solubility of $\text{Zn}_3(\text{PO}_4)_2$ in soil water.

$$[\text{Zn}^{2+}] = 3S \quad (1)$$

Total concentration of different phosphate species = $2S \text{ mol L}^{-1}$

$$[\text{PO}_4^{3-}] = f_3 \times 2S \quad (1)$$

f_3 can be determined from the relation derived in 2.3

$$\text{For pH} = 7, \quad f_3 = 1.83 \times 10^{-6} \quad (1)$$

$$K_{\text{sp}} = [\text{Zn}^{2+}]^3 [\text{PO}_4^{3-}]^2$$

$$9.1 \times 10^{-33} = (3S)^3 (f_3 \times 2S)^2 \quad (1)$$

$$\text{Solubility of } \text{Zn}_3(\text{PO}_4)_2 = 3.0 \times 10^{-5} \text{ mol L}^{-1} \quad (0.5)$$

$$[\text{Zn}^{2+}] = 9 \times 10^{-5} \text{ mol L}^{-1} \quad (0.5)$$

$$[\text{PO}_4^{3-}] = 1.1 \times 10^{-10} \text{ mol L}^{-1}$$

5 marks

Name :

Student code :

33rd IChO • Problem 3

8 Points

Second Law of Thermodynamics

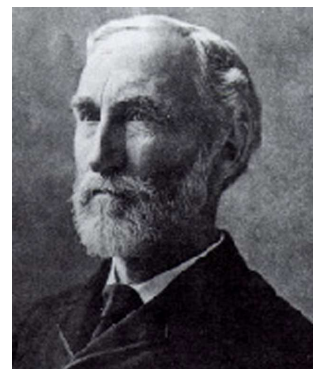

J.W.Gibbs (1839 –1903)

The Second Law of Thermodynamics is a fundamental law of science. In this problem we consider the thermodynamics of an ideal gas, phase transition and chemical equilibrium.

3.00 mol of CO₂ gas expands isothermally (in thermal contact with the surroundings; temperature = 15.0°C) against a fixed external pressure of 1.00 bar. The initial and final volumes of the gas are 10.0 L and 30.0 L, respectively.

3.1 Choose the correct option for change in the entropy of the system (ΔS_{sys}) and of the surroundings (ΔS_{sur}) :

- | | | | |
|-----|-----------------------------|-----------------------------|-------------------------------------|
| (a) | $\Delta S_{\text{sys}} > 0$ | $\Delta S_{\text{sur}} = 0$ | <input type="checkbox"/> |
| (b) | $\Delta S_{\text{sys}} < 0$ | $\Delta S_{\text{sur}} > 0$ | <input type="checkbox"/> |
| (c) | $\Delta S_{\text{sys}} > 0$ | $\Delta S_{\text{sur}} < 0$ | <input checked="" type="checkbox"/> |
| (d) | $\Delta S_{\text{sys}} = 0$ | $\Delta S_{\text{sur}} = 0$ | <input type="checkbox"/> |

[Mark X in the correct box.]

1 mark

3.2 Calculate ΔS_{sys} , assuming CO₂ to be an ideal gas.

Since ΔS_{sys} is independent of path, it is the same as for isothermal reversible expansion of an ideal gas.

$$\Delta S_{\text{sys}} = nR \ln \frac{V_f}{V_i} \quad (1)$$

$$= 27.4 \text{ JK}^{-1} \quad (1)$$

2 marks

3.3 Calculate ΔS_{sur}

$$q = p_{\text{ext}} \Delta V \quad (0.5)$$

$$\Delta S_{\text{sur}} = -\frac{q}{T} = -6.94 \text{ JK}^{-1} \quad (1)$$

1.5 marks

3.4 Calculate the change in entropy of the universe.

$$\Delta S_{\text{uni}} = \Delta S_{\text{sys}} + \Delta S_{\text{sur}}$$

$$= 20.5 \text{ JK}^{-1}$$

0.5 mark

Does your answer agree with the Second law of Thermodynamics?

[Mark X in the correct box.]



Yes



No

0.5 mark

The pressure – temperature phase diagram of CO_2 is given below schematically.
The diagram is not to scale.

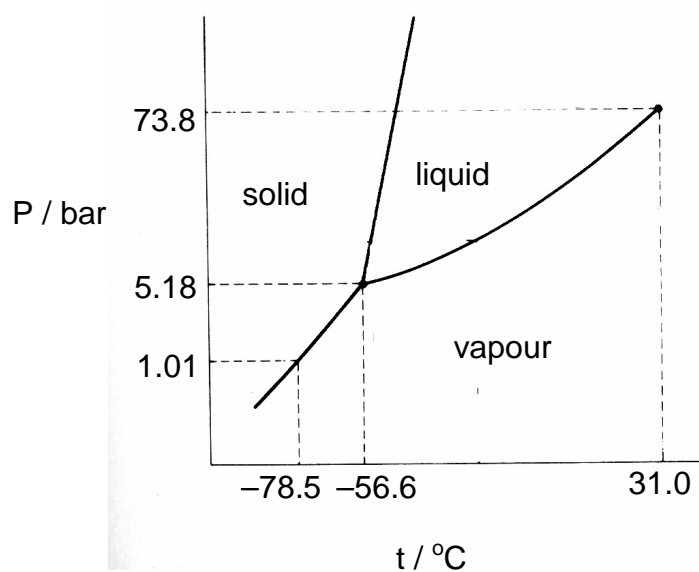
Phase diagram of CO_2

3.5 CO₂ gas, initially at a pressure of 4.0 bar and temperature of 10.0 °C, is cooled at constant pressure. In this process,

(a) it goes first to the liquid phase and then to the solid phase.

(b) it goes to the solid phase without going through the liquid phase.

[Mark X in the correct box.]

0.5 mark

3.6 Starting with the same pressure and temperature as above (in 3.5), CO₂ is compressed isothermally. In this process,

(a) it goes first to the liquid phase and then to the solid phase.

(b) it goes to the solid phase without going through the liquid phase.

[Mark X in the correct box.]

0.5 mark

3.7 From the data given in the phase diagram, calculate the molar enthalpy change of sublimation of CO₂. Write down the formula used.

$$\ln \frac{P_2}{P_1} = \frac{\Delta \bar{H}_{\text{sub}}}{R} \left(\frac{1}{T_1} - \frac{1}{T_2} \right) \quad (1)$$

$$\Delta \bar{H}_{\text{sub}} = 26.1 \text{ kJ mol}^{-1} \quad (1)$$

2 marks

- 3.8** CO gas, used extensively in organic synthesis, can be obtained by reacting CO₂ gas with graphite. Use the data given below to show that the equilibrium constant at 298.15 K is less than unity.

At 298.15 K

$$\text{CO}_2(\text{g}) : \quad \Delta H_f^\circ = -393.51 \text{ kJ mol}^{-1}; \quad S^\circ = 213.79 \text{ JK}^{-1} \text{ mol}^{-1}$$

$$\text{CO}(\text{g}) : \quad \Delta H_f^\circ = -110.53 \text{ kJ mol}^{-1}; \quad S^\circ = 197.66 \text{ JK}^{-1} \text{ mol}^{-1}$$

$$\text{C (graphite)} : \quad S^\circ = 5.74 \text{ JK}^{-1} \text{ mol}^{-1}$$

$$\Delta H^\circ = 172.45 \text{ kJ mol}^{-1} \quad (0.5)$$

$$\Delta S^\circ = 176 \text{ JK}^{-1} \text{ mol}^{-1} \quad (0.5)$$

$$\Delta G^\circ = \Delta H^\circ - T\Delta S^\circ = 120 \text{ kJ mol}^{-1} \quad (1)$$

$$\Delta G^\circ > 0 \text{ implies } K < 1 \quad (0.5)$$

2.5 marks

- 3.9** Estimate the temperature at which the reaction would have an equilibrium constant equal to 1. Ignore slight variations in the thermodynamic data with temperature.

$$\Delta G^\circ = 0 \text{ when } \Delta H^\circ = T\Delta S^\circ \quad (0.5)$$

$$T = 980 \text{ K} \quad (0.5)$$

1 mark

- 3.10** The reaction above (in **3.8**) is carried out between CO₂ and excess hot graphite in a reactor maintained at about 800°C and a total pressure of 5.0 bar. The equilibrium constant K_p under these conditions is 10.0. Calculate the partial pressure of CO at equilibrium.

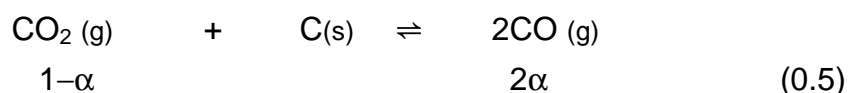

$$\begin{array}{ccc} \text{Partial} & \frac{1-\alpha}{1+\alpha} \times 5 & \frac{2\alpha}{1+\alpha} \times 5 & (1) \\ \text{pressure} & & & \end{array}$$

$$K_p = p^2(\text{CO}) / p(\text{CO}_2) \quad (0.5)$$

$$p(\text{CO}) = 3.7 \text{ bar} \quad (1)$$

3 marks

33rd IChO • Problem 4**6 Points****Beach Sand Mineral in Kerala**

Beach sand mineral, monazite, is a rich source of thorium, available in large quantities in the state of Kerala in India. A typical monazite sample contains about 9% ThO_2 and 0.35% U_3O_8 . ^{208}Pb and ^{206}Pb are the stable end-products in the radioactive decay series of ^{232}Th and ^{238}U , respectively. All the lead (Pb) found in monazite is of radiogenic origin.

The isotopic atom ratio $^{208}\text{Pb}/^{232}\text{Th}$, measured mass spectrometrically, in a monazite sample was found to be 0.104. The half-lives of ^{232}Th and ^{238}U are 1.41×10^{10} years and 4.47×10^9 years, respectively. Assume that ^{208}Pb , ^{206}Pb , ^{232}Th and ^{238}U remained entirely in the monazite sample since the formation of monazite mineral.

4.1 Calculate the age (time elapsed since its formation) of the monazite sample.

$$N = N_0 e^{-0.693 t / t_{1/2}}$$

$$\frac{N_0 - N}{N} = e^{+0.693 t / t_{1/2}} - 1$$

(1)

$(N_0 - N) =$ Total number of ^{232}Th atoms decayed.

$=$ Total number of ^{208}Pb atoms formed.

$$\frac{N_0 - N}{N} = 0.104$$

(1)

$$e^{0.693 t / 1.41 \times 10^{10}} = 1.104$$

$$t = 2.01 \times 10^9 \text{ years.}$$

(1)

3 marks

4.2 Estimate the isotopic atom ratio $^{206}\text{Pb}/^{238}\text{U}$ in the monazite sample.

Let x be the required ratio.

$$x = e^{+0.693 t / t_{1/2}} - 1$$

where $t = 2.01 \times 10^9$ years, (1)

and $t_{1/2} = 4.47 \times 10^9$ years.

$$x = 0.366 \quad (1)$$

2 marks

4.3 Thorium–232 is a fertile material for nuclear energy. In thermal neutron irradiation, it absorbs a neutron and the resulting isotope forms ^{233}U by successive β^- decays. Write the nuclear reactions for the formation of ^{233}U from ^{232}Th .

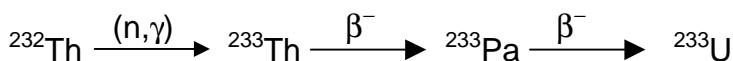

1 mark

In nuclear fission of ^{235}U a complex mixture of radioactive fission products is formed. The fission product ^{101}Mo initially undergoes radioactive decay as shown below:

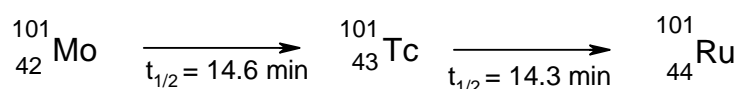

4.4 A freshly prepared radiochemically pure sample of ^{101}Mo contains 5000 atoms of ^{101}Mo initially. How many atoms of

i) ^{101}Mo

ii) ^{101}Tc

iii) ^{101}Ru

will be present in the sample after 14.6 min?

- (i) The number of atoms of ^{101}Mo (N_1) in the sample after one half-life is :

$$N_1 = 2500 \quad (0.5)$$

- (ii) The number of atoms of ^{101}Tc (N_2) is given by

$$N_2 = \frac{\lambda_1 N_0}{\lambda_2 - \lambda_1} (e^{-\lambda_1 t} - e^{-\lambda_2 t})$$

where $N_0 (= 5000)$ is the initial number of atoms of ^{101}Mo .

$$\lambda_1 = \frac{0.693}{14.6} \text{ min}^{-1}$$

$$\lambda_2 = \frac{0.693}{14.3} \text{ min}^{-1}$$

At $t = 14.6$ min

$$N_2 = 1710 \quad (1)$$

- (iii) Number of atoms of ^{101}Ru (N_3) at $t = 14.6$ min is :

$$N_3 = N_0 - N_1 - N_2$$

$$= 790 \text{ atoms} \quad (0.5)$$

2 marks

[3 % variation in answers to N_2 and N_3 will be permitted.]

Name :

Student code :

33rd IChO • Problem 5

11 Points

Halogen Chemistry

Halogens in their reactions among themselves and with a variety of other elements give rise to a large number of compounds with diverse structure, bonding and chemical behaviour. Metal halides, halogen derivatives and interhalogens represent major types of halogen compounds.

(A) Photography

A “black and white” photographic film contains a coating of silver bromide on a support such as cellulose acetate.

- 5.1** Write the photochemical reaction that occurs when light falls on AgBr(s) coated on a film.

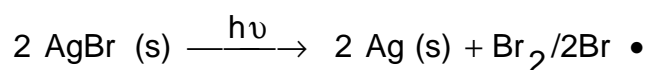

0.5 mark

- 5.2** During the developing process, unexposed AgBr is washed away by complexation of Ag(I) by sodium thiosulphate solution. Write down this chemical equation.

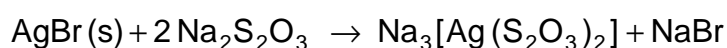

1 mark

- 5.3** These washings are often disposed of as waste. However, metallic silver can be recovered from them by adding cyanide, followed by zinc. Write down the reactions involved.

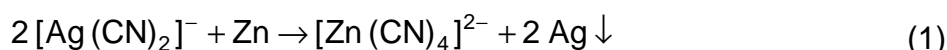
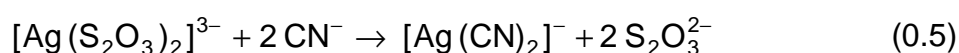

1.5 marks

(B) Shapes, spectra and reactivity

The most reactive halogen, fluorine, reacts with other halogens, Cl_2 , Br_2 , and I_2 under controlled conditions giving a tetra-atomic, hexa-atomic and an octa-atomic molecule, respectively.

5.4 Write the formulae and 3 dimensional structures of these interhalogen molecules on the basis of VSEPR theory. Show the disposition of the lone pairs on the central atom, where appropriate.

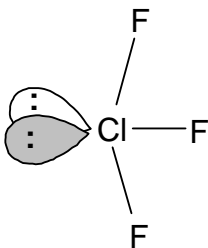
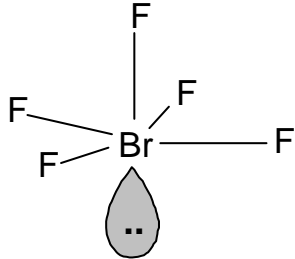
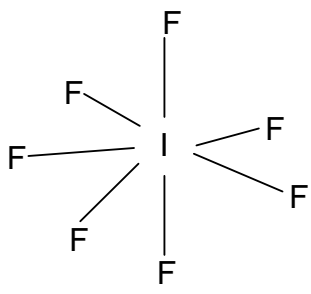
Formula	Structure
ClF_3 (0.5)	 (1)
BrF_5 (0.5)	 (0.5)
IF_7 (0.5)	 (0.5)

3.5 marks

A mixture of iodine vapour and chlorine gas when fed into a mass spectrometer gave two sets (A and B) of mass spectral peaks corresponding to molecular ions of two chemical species at m/z :

A : (162,164)

B : (464, 466, 468, 470, 472, 474, 476)

- 5.5 Identify the molecular species corresponding to $m/z = 162, 164, 466$ and 476 . Draw the structure of the heaviest species ($m/z = 476$) indicating clearly the lone pairs on I atom(s). Show the isotopic composition of each species.

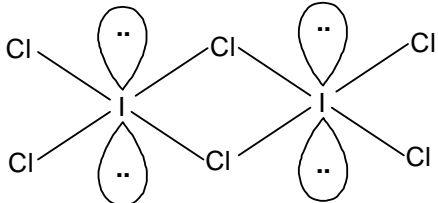
Mass	Species		
162	$I^{35}Cl$	(0.5)	
164	$I^{37}Cl$	(0.5)	
466	$I_2^{35}Cl_5^{37}Cl$	(0.5)	
476	$I_2^{37}Cl_6$	(0.5)	

3 marks

In aqueous medium chlorine gas oxidises sodium thiosulphate to an ion containing the highest oxidation state of sulphur.

- 5.6 Write down the chemical equation for this reaction.

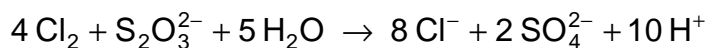

1 mark

- 5.7 Write down the Lewis dot structure of the thiosulphate ion. Circle the sulphur atom that has the lower oxidation state.

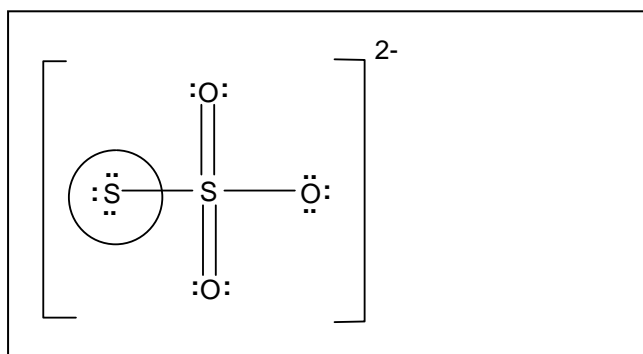

1 mark

- 5.8 Chlorine dioxide reacts with sodium hydroxide as shown below. Identify the products X and Y (both containing chlorine) and balance the equation.

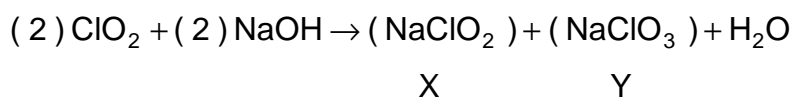

2 marks

- 5.9 Reaction of chlorine and an alkali is used for manufacturing bleach. Write the chemical reaction for its formation.

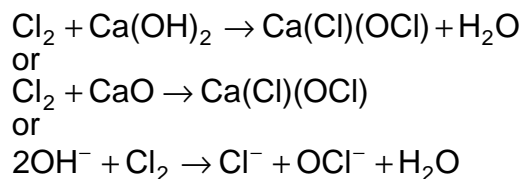

1 mark

- 5.10 The oxidation state(s) of chlorine in bleach is (are):

-1 and +1

1 mark

(C) Alkali metal halides and X-ray crystallography

X-ray crystallography reveals many aspects of the structure of metal halides. The radius ratio (r_+/r_-) is a useful parameter to rationalize their structure and stability. A table of radius ratio (r_+/r_-) for some alkali halides is given below. The variation of the electrostatic component of lattice energy of alkali halides with radius ratio (r_- kept constant) is shown schematically for NaCl-type and CsCl-type crystal structures.

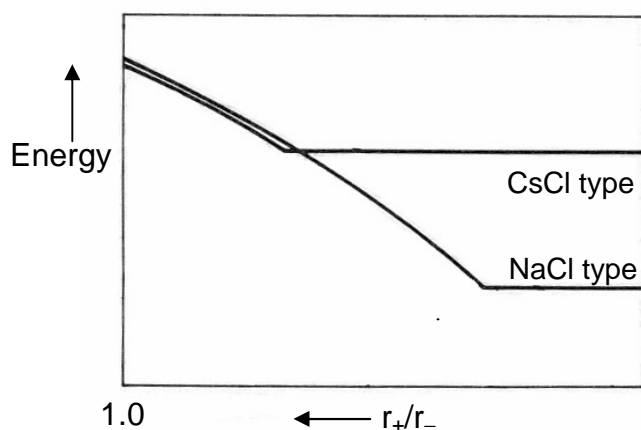

	Li ⁺	Na ⁺	K ⁺	Rb ⁺	Cs ⁺
Cl ⁻	0.33	0.52	0.74	0.82	0.93
Br ⁻	0.31	0.49	0.68	0.76	0.87
I ⁻	0.28	0.44	0.62	0.69	0.78

- 5.11 For a given anion, the graph for NaCl-type structure levels off at low r_+/r_- values because of

- (a) cation–cation contact along the face diagonal.
- (b) anion–anion contact along the face diagonal.
- (c) cation–anion contact along the cell edge.

[Mark X in the correct box.]

1 mark

- 5.12 Which among the halides LiBr, NaBr and RbBr is likely to undergo phase transition from NaCl-type to CsCl-type structure with change of temperature and /or pressure?

RbBr

0.5 mark

- 5.13 Show by calculation the radius ratio (r_+/r_-) at which the energy of CsCl-type structure levels off.

In CsCl-type structure,

Cell edge, $a = 2r_-$ (0.5)

Body diagonal, $\sqrt{3}a = 2(r_+ + r_-)$ (0.5)

$$\frac{r_+}{r_-} = \sqrt{3} - 1 = 0.732 \quad (0.5)$$

1.5 marks

- 5.14 Using Cu K α X-rays ($\lambda = 154$ pm), diffraction by a KCl crystal (fcc structure) is observed at an angle (θ) of 14.2° . Given that (i) diffraction takes place from the planes with $h^2 + k^2 + l^2 = 4$, (ii) in a cubic crystal $d_{hkl} = a / (h^2 + k^2 + l^2)^{1/2}$, where 'd' is the distance between adjacent hkl planes and 'a' is the lattice parameter, and (iii) reflections in an fcc structure can occur only from planes with 'all odd' or 'all even' hkl (Miller) indices, calculate the lattice parameter 'a' for KCl.

$$\lambda = 2d \sin \theta \quad (0.5)$$

$$d_{200} = \frac{\lambda}{2 \sin \theta} = 314 \text{ pm} \quad (0.5)$$

$$d_{200} = \frac{a}{(h^2 + k^2 + l^2)^{1/2}} = \frac{a}{(2^2 + 0^2 + 0^2)^{1/2}} = \frac{a}{2} \quad (0.5)$$

$$a = 628 \text{ pm} \quad (0.5)$$

2 marks

- 5.15 Indicate in the table given below the required information for the 2nd and 3rd nearest neighbours of a K⁺ ion in the KCl lattice.

2 nd nearest neighbours			3 rd nearest neighbours		
number	sign of the charge	distance (pm)	number	sign of the charge	distance (pm)
12	+	444	8	-	544

3 marks

- 5.16 Determine the lowest value of diffraction angle θ possible for the KCl structure.

Lowest θ value is for the plane with hkl = (111)	(0.5)
$\therefore d = \frac{a}{\sqrt{1^2 + 1^2 + 1^2}} = \frac{628}{\sqrt{3}} = 363 \text{ pm}$	(0.5)
$\sin \theta_{111} = \frac{\lambda}{2d_{111}} = \frac{154 \text{ pm}}{2 \times 363 \text{ pm}} = 0.212$	(0.5)
$\therefore \theta_{111} = 12.2^\circ$	(0.5)

2 marks

Name :

Student code :

33rd IChO • Problem 6

12 Points

Organic chemistry of Indian spices



The rhizomes of ginger (*Zingiber officinale*) are well known for their medicinal and flavoring properties. In Ayurveda (the traditional system of medicine in India), different formulations of ginger are used for the treatment of gastrointestinal problems, common cold and other ailments. Several compounds are responsible for the pungency of ginger. Many are simple substituted aromatic compounds with different side chains. Three of them, Zingerone, (+)[6] Gingerol (to be referred hereafter as Gingerol only), and Shogaol are particularly important.

Zingerone $C_{11}H_{14}O_3$

Gingerol $C_{17}H_{26}O_4$

Shogaol $C_{17}H_{24}O_3$

6.1 Zingerone gives positive $FeCl_3$ and 2,4-DNP (2,4-dinitrophenylhydrazine) tests. It does not react with Tollen's reagent. Therefore, Zingerone contains the following functional groups: [Mark X in the correct boxes.]

(a) alcoholic hydroxyl

(e) ester

(b) aldehydic carbonyl

(f) alkoxy

(c) ketonic carbonyl

(g) unsaturation

(d) phenolic hydroxyl

The data obtained from the ^1H NMR spectrum of Zingerone are shown in Table 1. Some other relevant information is given in Table 2.

Table 1 : ^1H NMR spectral data* on Zingerone

Chemical shifts (δ)	Multiplicity	Relative intensity
2.04	singlet	3
2.69,271	two (closely spaced) triplets of equal intensity	4
3.81	singlet	3
5.90	broad singlet (D_2O exchangeable)	1
6.4 – 6.8	two doublets with similar chemical shifts and one singlet	3

(* For clarity, some of the data have been altered slightly.)

Table 2 : Approximate ^1H chemical shifts (δ) and spin–spin coupling constants (J) of some protons.

^1H Chemical shifts (δ)			
alkyl -H	0.9 - 1.5		3.4 - 3.6
	2.0 - 2.7		4.0 - 7.0
Ph-CH<	2.3 - 2.9	Ph-H	6.0 - 8.0
-O-CH<	3.3 - 3.9	Ar-OH	4.0 - 11.0

Spin–spin coupling constants (J)

Alkenes	<i>cis</i>	5 – 14 Hz (commonly around 6 – 8 Hz)
	<i>trans</i>	11– 19 Hz (commonly around 14 – 16 Hz)

Zingerone on bromination with bromine water gives only one nuclear mono brominated product. The IR spectrum of Zingerone indicates the presence of a weak *intramolecular* hydrogen bond. The same is present even after Clemmensen reduction (Zn–Hg/HCl) of Zingerone.

6.2 From the information above deduce the following :

i. side chain in Zingerone

CH₂CH₂COCH₃

ii. substituents on the aromatic ring

OH, OCH₃

iii. relative positions of the substituents on the ring

1, 2, 4

3 marks

6.3 Draw a possible structure of Zingerone based on the above inferences.

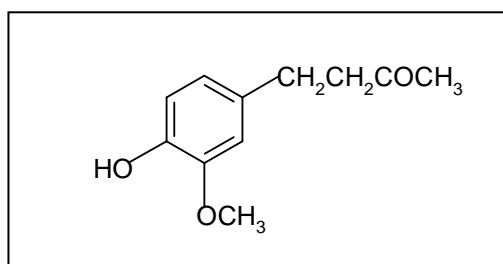

3 marks

[Inference from mono bromination : 1 mark ; Inference from IR : 1 mark ; Inference from Clemmensen reduction : 1 mark]

6.4 Complete the following reaction sequence for the synthesis of Zingerone.

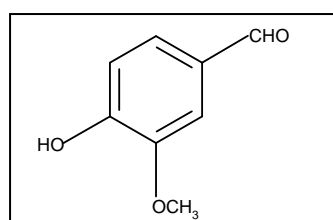

A

+

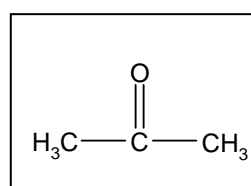

B(C₃H₆O)

aq. NaOH

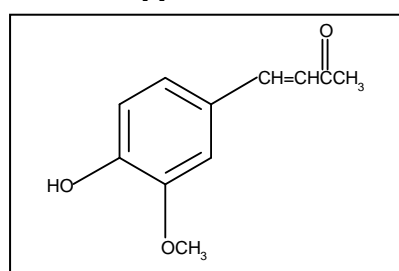

C

H₂/Catalyst

Zingerone

(C₁₁H₁₄O₃)

[copy structure 6.4 A to page 30]

[Inference on C from Zingerone: 1 mark ; Inference on A and B from C: 2 marks] 3 marks

- 6.5 Zingerone can be easily converted into Gingerol by the following reaction sequence :

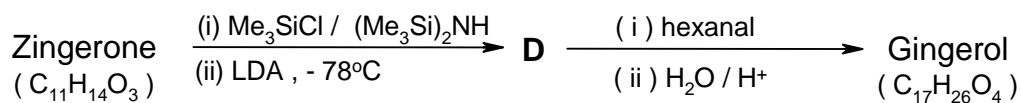

- Notes : (1) $\text{Me}_3\text{SiCl / (Me}_3\text{Si)}_2\text{NH}$ is used to convert OH into $-\text{OSiMe}_3$; the group $-\text{SiMe}_3$ can be removed by acid hydrolysis.
 (2) LDA is lithium diisopropylamide, a strong, very hindered, non-nucleophilic base.

- i. Draw the structure of **D**.

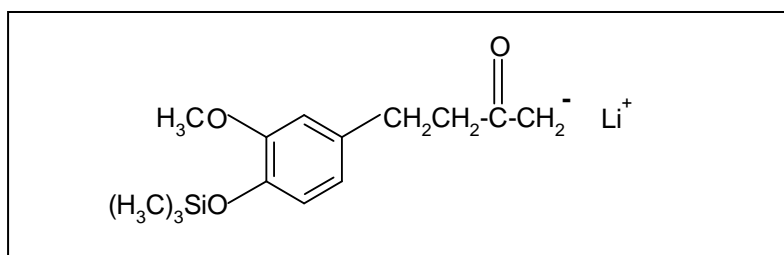

2 marks

[Inference from LDA, -78°C : 2 marks ; Inference from only LDA as a base: 1 mark]

- ii. Draw the structure of Gingerol.

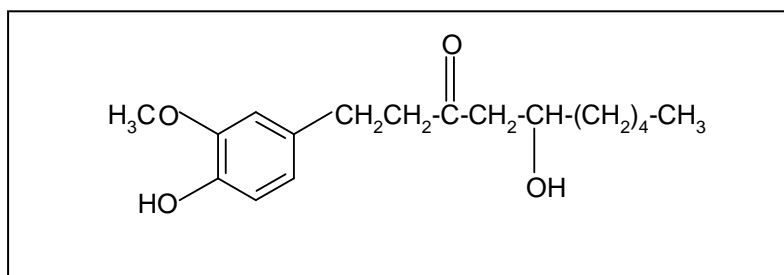

2 marks

[Addition of hexanal to the side chain: 1 mark]

- iii. Complete the Fischer projection of the *R*-enantiomer of Gingerol.

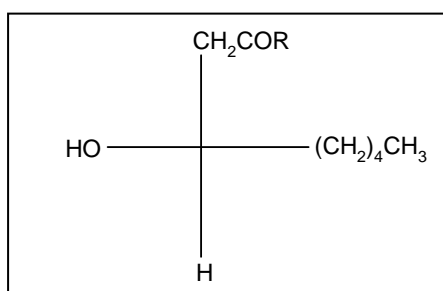

1 mark

[Fischer projection of (ii): 1 mark]

- iv. In the above reaction sequence (6.5), about 2–3% of another constitutional isomer (**E**) of Gingerol is obtained. Draw the likely structure of **E**.

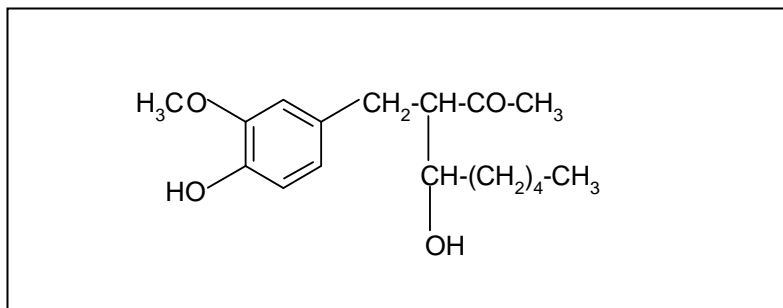

1 mark

[Notion of positional isomer: 1 mark]

- v. Will the compound **E** be formed as

(a) a pair of enantiomers?

(b) a mixture of diastereomers?

(c) a mixture of an enantiomeric pair and a meso isomer?

[Mark X in the correct box.]

1 mark

- vi. Gingerol ($C_{17}H_{26}O_4$) when heated with a mild acid (such as $KHSO_4$) gives Shogaol ($C_{17}H_{24}O_3$). Draw the structure of Shogaol.

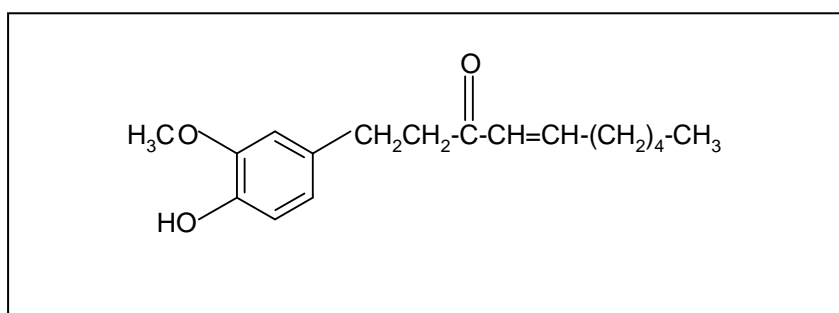

1 mark

[Indication of plausible dehydration: 1 mark]

- 6.6 Turmeric (*Curcuma longa*) is a commonly used spice in Indian food. It is also used in Ayurvedic medicinal formulations. Curcumin ($C_{21}H_{20}O_6$), an active ingredient of turmeric, is structurally related to Gingerol. It exhibits keto–enol tautomerism. Curcumin is responsible for the yellow colour of turmeric and probably also for the pungent taste.

The ^1H NMR spectrum of the keto form of Curcumin shows aromatic signals similar to that of Gingerol. It also shows a singlet around δ 3.5 (2H) and two doublets (2H each) in the region δ 6–7 with $J = 16$ Hz. It can be synthesized by condensing **TWO** moles of **A** (refer to 6.4) with one mole of pentan-2,4-dione.

i. Draw the stereochemical structure of Curcumin.

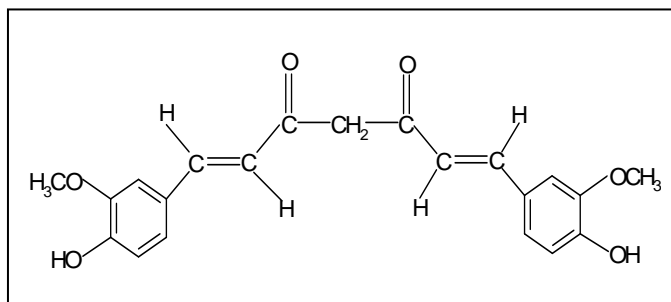
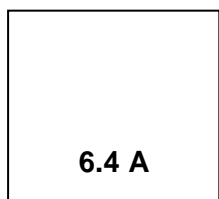

3 marks

[Inference from NMR: COCH_2CO :0.5 mark; $\text{C}=\text{C}$: 0.5 mark; *trans* stereochemistry: 1 mark; condensation with dione: 1 mark]

ii. Draw the structure of the enol form of Curcumin

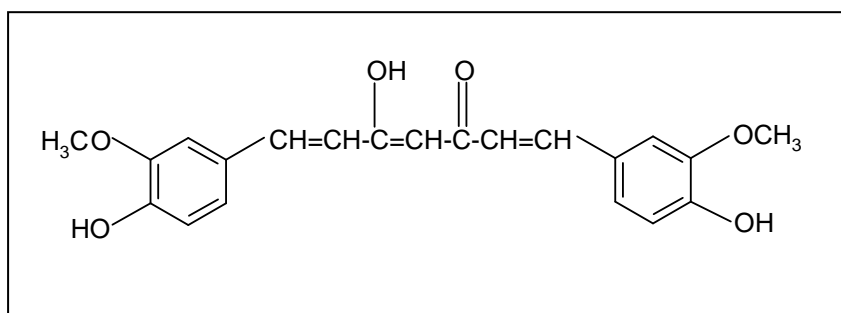

1 mark

iii. Curcumin is yellow in colour because it has

- | | |
|-----------------------------|-------------------------------------|
| (a) a phenyl ring | <input type="checkbox"/> |
| (b) a carbonyl group | <input type="checkbox"/> |
| (c) an extended conjugation | <input checked="" type="checkbox"/> |
| (d) a hydroxyl group | <input type="checkbox"/> |

1 mark

Name :

Student code :

33rd IChO • Problem 7

9 Points

Peptides and Proteins

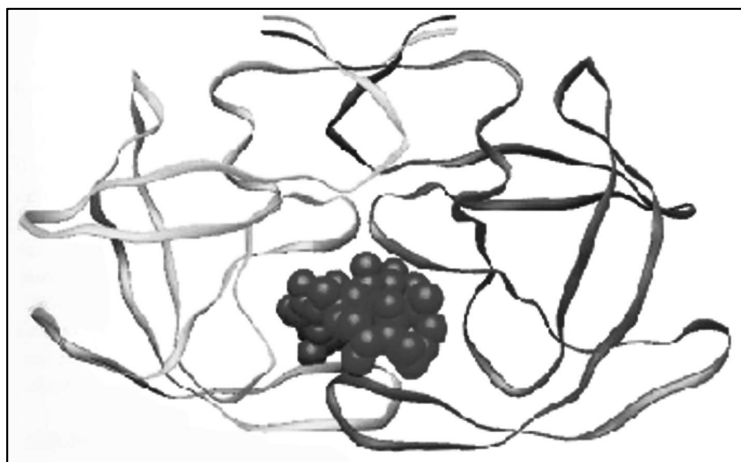

Protein folding

Proteins (polypeptides) are known to assume a variety of backbone conformations. In one conformation, the backbone is in almost fully extended arrangement (as in a parallel or anti-parallel β -sheet), and in another conformation it is in a fully folded arrangement (as in an α -helix).

7.1 The end-to-end distance in a hexapeptide when it is in a fully extended conformation is approximately :

(a) 10 Å

(b) 15 Å

(c) 20 Å

(d) 25 Å

1 mark

[Mark X in the correct box.]

Amino Acid	Structure	Molecular mass (Da)
Glu – Glutamic acid	$\begin{array}{c} \text{COO}^- \\ \\ \text{H}_3\text{N}^+ - \text{C} - \text{CH}_2 - \text{CH}_2 - \text{COOH} \\ \\ \text{H} \end{array}$	147
Hms – Homoserine	$\begin{array}{c} \text{COO}^- \\ \\ \text{H}_3\text{N}^+ - \text{C} - \text{CH}_2 - \text{CH}_2 - \text{OH} \\ \\ \text{H} \end{array}$	119
Leu – Leucine	$\begin{array}{c} \text{COO}^- \\ \\ \text{H}_3\text{N}^+ - \text{C} - \text{CH}_2 - \text{CH} \begin{array}{l} / \text{CH}_3 \\ \backslash \text{CH}_3 \end{array} \\ \\ \text{H} \end{array}$	131
Met – Methionine	$\begin{array}{c} \text{COO}^- \\ \\ \text{H}_3\text{N}^+ - \text{C} - \text{CH}_2 - \text{CH}_2 - \text{S} - \text{CH}_3 \\ \\ \text{H} \end{array}$	149
Lys – Lysine	$\begin{array}{c} \text{COO}^- \\ \\ \text{H}_3\text{N}^+ - \text{C} - \text{CH}_2 - \text{CH}_2 - \text{CH}_2 - \text{CH}_2 - \text{NH}_2 \\ \\ \text{H} \end{array}$	146
Phe – Phenylalanine	$\begin{array}{c} \text{COO}^- \\ \\ \text{H}_3\text{N}^+ - \text{C} - \text{CH}_2 - \text{C}_6\text{H}_5 \\ \\ \text{H} \end{array}$	165
Arg – Arginine	$\begin{array}{c} \text{COO}^- \\ \\ \text{H}_3\text{N}^+ - \text{C} - \text{CH}_2 - \text{CH}_2 - \text{CH}_2 - \text{NH} - \text{C} \begin{array}{l} / \text{NH}_2 \\ \backslash \text{NH} \end{array} \\ \\ \text{H} \end{array}$	174
Ser – Serine	$\begin{array}{c} \text{COO}^- \\ \\ \text{H}_3\text{N}^+ - \text{C} - \text{CH}_2 - \text{OH} \\ \\ \text{H} \end{array}$	105

- 7.2 Assuming that the following hexapeptide is in α -helix conformation, draw a connecting arrow between an oxygen atom and an amide NH with which it is hydrogen bonded.

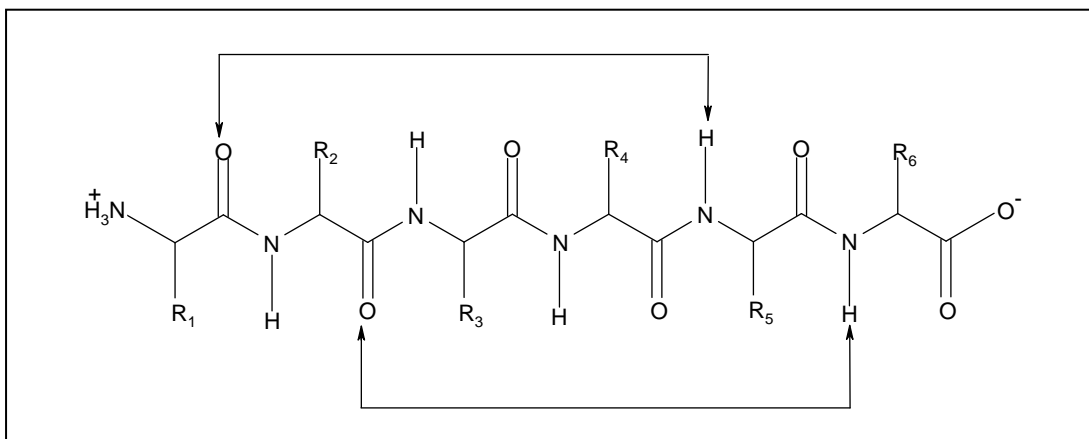

[1 mark for any correct answer; 0 for any wrong connections]

1 mark

- 7.3 The following two hexapeptides (**A** and **B**) display contrasting conformations in water at pH 7.0, especially when their serine hydroxyls are phosphorylated. **A** is moderately helical and it becomes a stronger helix on serine phosphorylation. **B** is weakly helical and it is completely disordered on serine phosphorylation. Draw connecting arrows to indicate the interactions between the residues that are responsible for this differing behaviour.

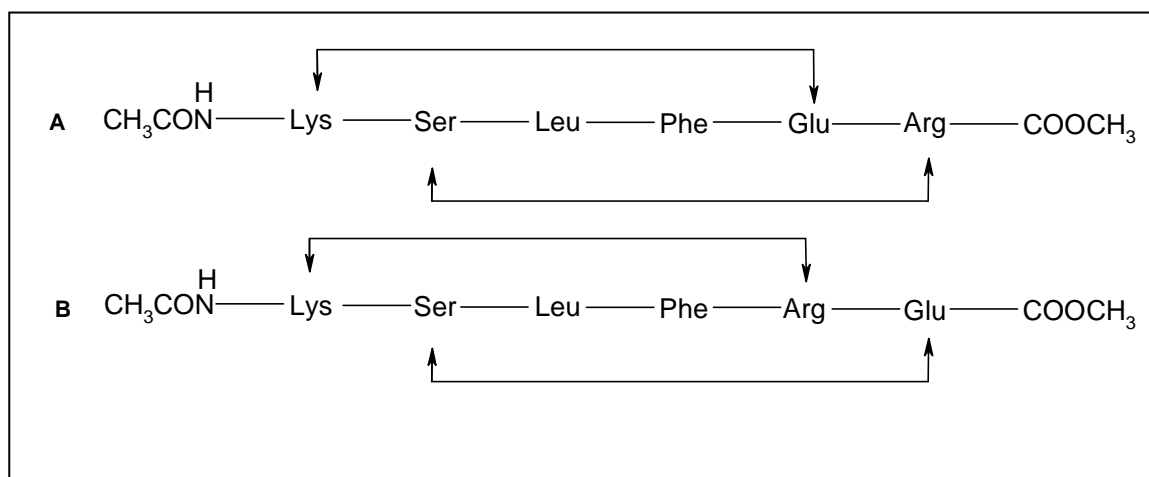

[0.5 mark for each correct arrow]

2 marks

Consider the following process of folding/unfolding of a tripeptide segment in a large protein. The free energy change (ΔG) will depend on the interaction of the unfolded tripeptide with the solvent (water) and with the rest of the protein in the folded state (see below). Assume that the tripeptide is made up of one non-polar (hydrophobic; shaded) and two polar (hydrophilic; unshaded) residues. Assume the following

approximate changes in the interaction free energies :

- (a) a non-polar residue and the solvent (water)
 $\Delta G = +8 \text{ kJ mol}^{-1}$
- (b) a non-polar residue and the rest of the protein
 $\Delta G = -4 \text{ kJ mol}^{-1}$
- (c) a polar residue and the solvent (water)
 $\Delta G = -16 \text{ kJ mol}^{-1}$
- (d) a polar residue and the rest of the protein
 $\Delta G = -14 \text{ kJ mol}^{-1}$

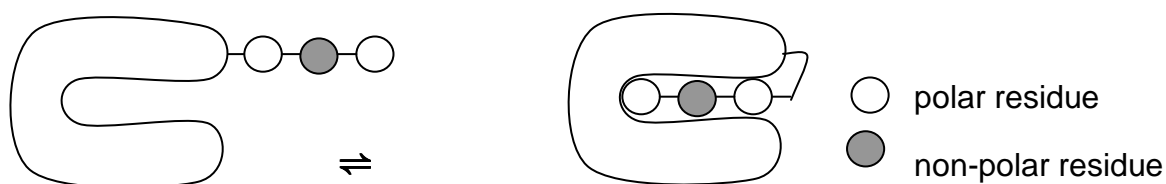

Tripeptide segment in unfolded form

Tripeptide segment in folded form

7.4 Calculate ΔG for the folding of the tripeptide segment.

$$\Delta G = -8 - (-16 \times 2) + (-4 \times 1) + (-14 \times 2) = -8 \text{ kJ mol}^{-1}$$

1 mark

7.5 Calculate ΔG for the folding of the tripeptide segment if all the three residues are polar.

$$\Delta G = -(14 \times 3) - (-16 \times 3) = +6 \text{ kJ mol}^{-1}$$

0.5 mark

β – lactamase and drug resistance

Penicillins are effective drugs in combating bacterial infections. An alarming development over the years has, however, been the emergence of drug resistant bacteria. Penicillin resistance arises due to the secretion of an enzyme called β -lactamase (also known as penicillinase), which inactivates penicillin by opening its β -lactam ring. The mechanism for this β -lactam ring opening involves the nucleophilic attack by serine-OH at the active site of the enzyme as shown below.

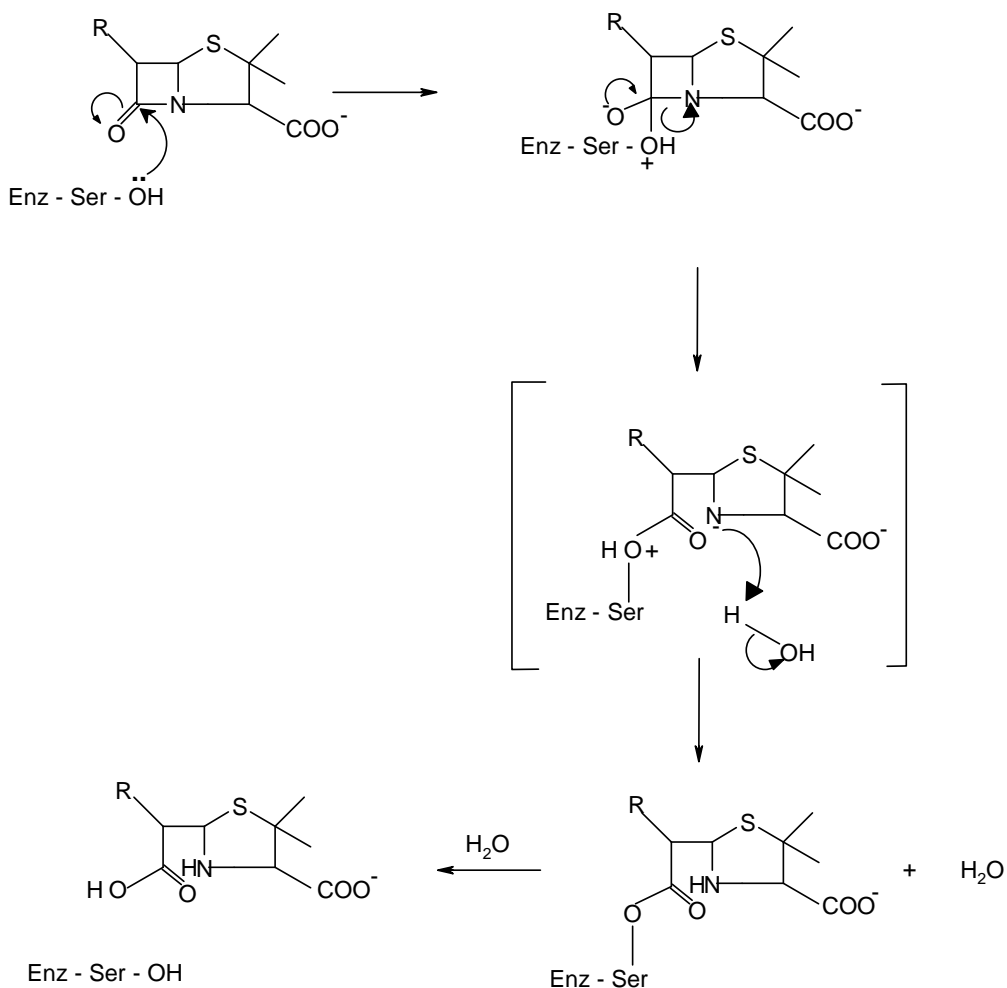

An attempt was made to characterize the β -lactamase from *Staphylococcus aureus*. When the pure enzyme was treated with a radiolabelled [³²P] phosphorylating agent, only the active site serine got labelled. On analysis, this serine {molecular mass = 105 mass units (Da)} constituted 0.35% by weight of the β -lactamase.

7.6 Estimate the minimal molecular mass of this β -lactamase.

$$\frac{105 \times 100}{0.35} = 30000 \text{ Da}$$

1 mark

7.7 The approximate number of amino acid residues present in a protein of this size is :

- (a) 100
- (b) 150
- (c) 275
- (d) 375

[Mark X in the correct box.]

1 mark

7.8 To map its active site, the β -lactamase was hydrolysed using trypsin, a specific enzyme.

This resulted in a hexapeptide P1 containing the active site serine. Amino acid analysis revealed the following in equimolar proportion : Glu, Leu, Lys, Met, Phe and Ser.

Treatment of P1 with Edman's reagent (phenyl isothiocyanate) yielded phenyl thiohydantoin (PTH) derivative of phenylalanine and a peptide P2.

Treatment of P1 with cyanogen bromide (CNBr) gave an acidic tetrapeptide P3 and a dipeptide P4.

Treatment of P2 with 1-fluoro-2,4-dinitrobenzene, followed by complete hydrolysis, yielded N-2,4-dinitrophenyl-Glu.

P1, P2, and P3 contain the active site serine.

From the above information, deduce the amino acid sequence of P1, P2, P3 and P4.

P1 : Phe – Glu – Ser – Met – Leu – Lys	
P2 : Glu – Ser – Met – Leu – Lys	
P3 : Phe – Glu – Ser – Hms/Met	
P4 : Leu – Lys	Hms = 1; Met = 0.5

4 marks

- 7.9 Calculate the molecular mass of P3 in mass units (Da) from the information given in the Table on page 32.

Phe – Glu – Ser – Hms $(165 + 147 + 105 + 119) - 3\text{H}_2\text{O}$ $= 536 - 54 = 482 \text{ Da}$

(1 mark : – 3H₂O)

1 mark

- 7.10 The β -lactamase active site provides a unique microenvironment that makes the catalytic serine–OH an unusually reactive nucleophile. The first order rate constant for β -lactamase catalysed reaction is 350 s^{-1} . For penicillin hydrolysis by free serine–OH (at 1M) in solution, the pseudo first order rate constant is 0.5 s^{-1} .

From the information above, calculate the effective concentration of this nucleophile at the enzyme active site?

700 M

1 mark

- 7.11 A molecule competing with penicillin for binding to the β -lactamase active site can inhibit the enzyme. Dissociation constants (K_D) for the inhibitor–lactamase complex for three different inhibitors are given below :

Inhibitor	Dissociation constant (K_D)
A	2.0×10^{-3}
B	1.0×10^{-6}
C	5.0×10^{-9}

Indicate which of these inhibitors is most effective in protecting penicillin against β -lactamase. [Mark X in the correct box]

A	<input type="checkbox"/>
B	<input type="checkbox"/>
C	<input checked="" type="checkbox"/>

1 mark

A β -lactamase inhibitor was designed rationally. On binding to the enzyme active site, a nucleophilic attack by the OH group of serine resulted in the opening of the β -lactam moiety of the inhibitor and elimination of Br^- . A reactive electrophile is generated as a result and it captures an active site residue X, inactivating the enzyme.

7.12 Based on the above information, identify the electrophile (A) generated and the final product (B) formed in the enzyme inactivation by the inhibitor shown.

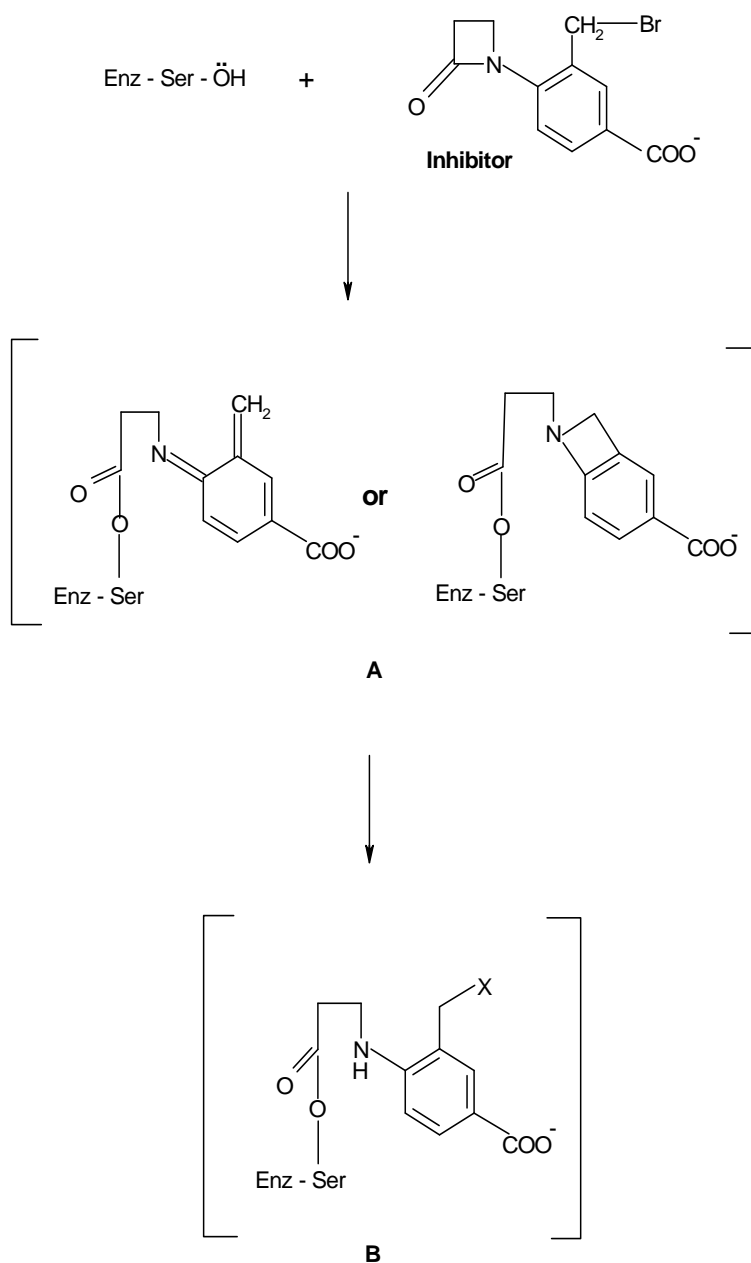

3 marks